

# Mounting instructions for ARCUSAFLEX flywheel couplings

## Type AC-T...F2 with taper bush

### How to mount the taper bush

1. The outer taper of the taper bush and the bore with the inner taper of the element hub shall show bright metal and must be free of grease prior to mounting. Preservatives shall be removed completely.
2. Insert the taper bush into the element hub and line up all connecting bores. Make sure that half threaded bores coincide with half plain bores (Fig. 1).
3. Screw in lightly greased or oiled assembly screws. Do not tighten the screws yet (Fig. 2).
4. Slide the element hub with inserted taper bush onto the cleaned shaft with keyway and put it into the mounting position  $L_x$  (Fig. 3).
5. Tighten the screws uniformly up to the tightening torque  $M_{A2}$  specified in table 2 using a torque wrench.
6. The screws can be retightened again by tapping against the taper bush with a hammer using an intermediate plate. Repeat, if necessary.

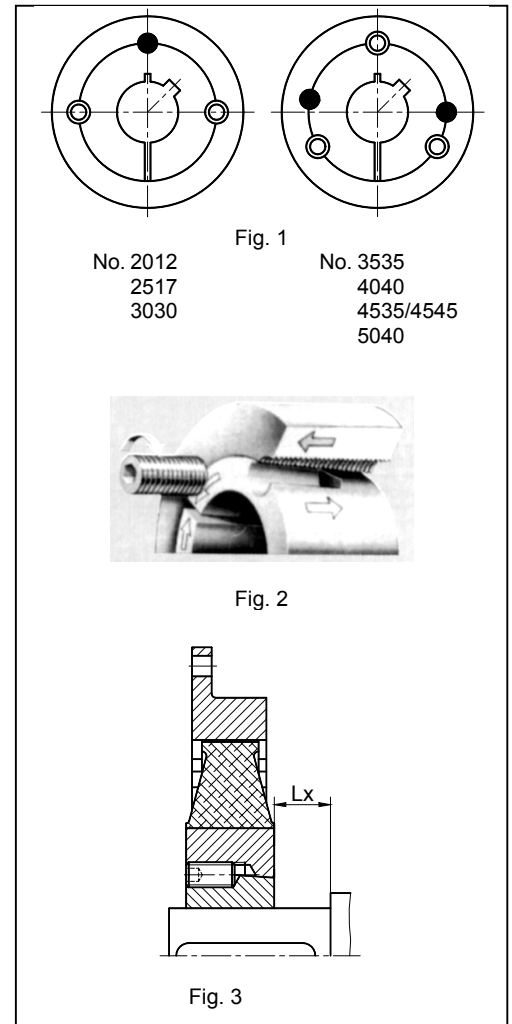

### Tightening torques for mounting the taper bush

**Table 2**

Coupling size	AC-T 2,3	AC-T 2,6 AC-T 3	AC-T 4	AC-T 5	AC-T 6	AC-T 6,5 AC-T 7	AC-T 8 AC-T 9
Taper bush No.	2012	2517	3030	3535	4040	4535 4545	5040
B.S.W. screw size *)	$\frac{7}{16} \times 22$	$\frac{1}{2} \times 25$	$\frac{5}{8} \times 32$	$\frac{1}{2} \times 38$	$\frac{5}{8} \times 45$	$\frac{3}{4} \times 50$	$\frac{7}{8} \times 57$
Tightening torque $M_{A2}$ [Nm]	31	49	92	115	172	195	271
Width across flats SW [mm]	6	6	8	10	12	14	14

\*) No. 2012/2517/3030 set screw  
No. 3535/4040/4535/4545/5040 cap screw

### How to remove the element hub with taper bush

1. Loosen and remove all screws. Depending on the taper bush size, screw either 1 or 2 greased screws into the half pulling-off thread(s) of the taper bush (Fig. 4).
2. Tighten the screws uniformly until the taper bush is loose in the element hub.
3. As soon as the taper bush is loose, the element hub can be pulled off the shaft together with the taper bush.

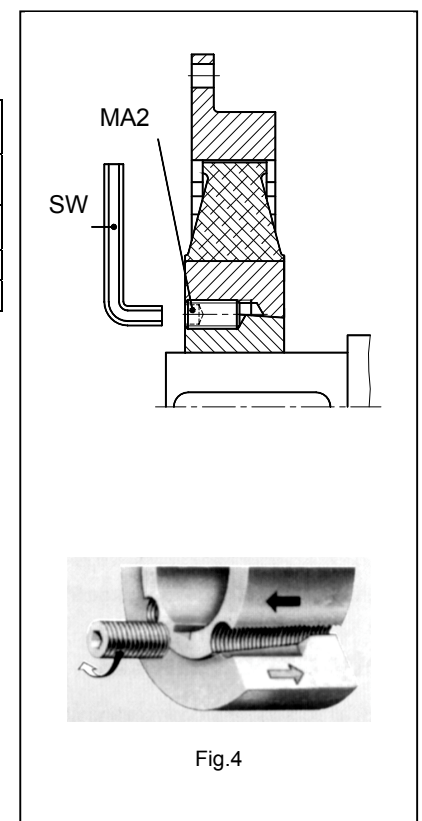

# Tightening torques for ARCUSAFLEX flywheel couplings

All bolts and screws must be tightened to the specified torques during assembly in order to ensure a reliable torque transmission. Prior to putting the machinery into operation, all bolts and screws of the coupling must be checked for proper fit.

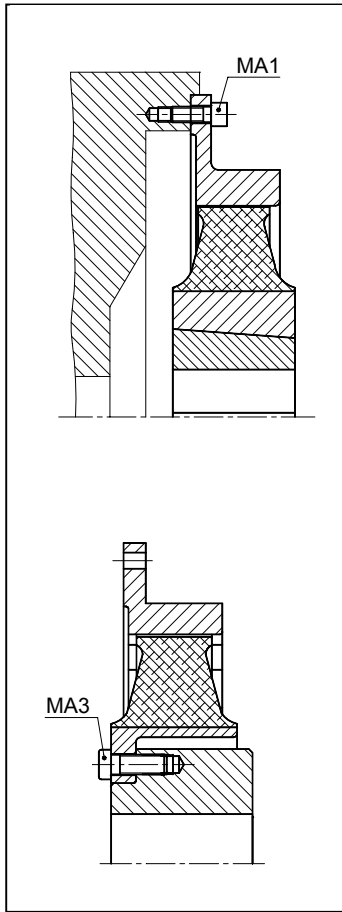

**Table 1**

Tightening torques for the bolted flange connection to the engine flywheel (grade 8.8)

SAE flywheel flange	6 ½	7 ½	8	10	11 ½	14	16	18	21	24
Metric bolts	M8		M10			M12		M16		M20
Tightening torque M <sub>A1</sub> [Nm]	25		50			85		210		420
Imperial size bolts	5/16 - 18		3/8 - 16			1/2 - 13		5/8 - 11		3/4 - 10
Tightening torque M <sub>A1</sub> [Nm]	24		42			102		203		340

Note: The aluminum flanges of the coupling sizes AC 2,3 – AC 10D have to be mounted only with bolts of grade 8.8. Alternative bolts of grade 10.9 with suitable washer and the corresponding tightening torque can be used (if needed please reconsult us).

**Table 3**

Tightening torques for the bolted hub connection  
Types AC...F2 and AC F2.K (grade 8.8)

Coupling size	AC 2,3	AC 2,6 AC 3 AC 4/4.1	AC 5/5.1 AC 6/6.1 AC 6,5	AC 7 AC 8 / AC 8D AC 9 / AC 9D		AC 10 / AC 10D AC 11 / AC 11D AC 11,6 / AC 12		AC 12D
Bolt size (metric)	M8	M12	M16	M16	M20	M20	M24	M24 (10.9)
Tightening torque M <sub>A3</sub> [Nm]	25	85	210	210	420	420	710	1000

## ARCUSAFLEX shaft couplings

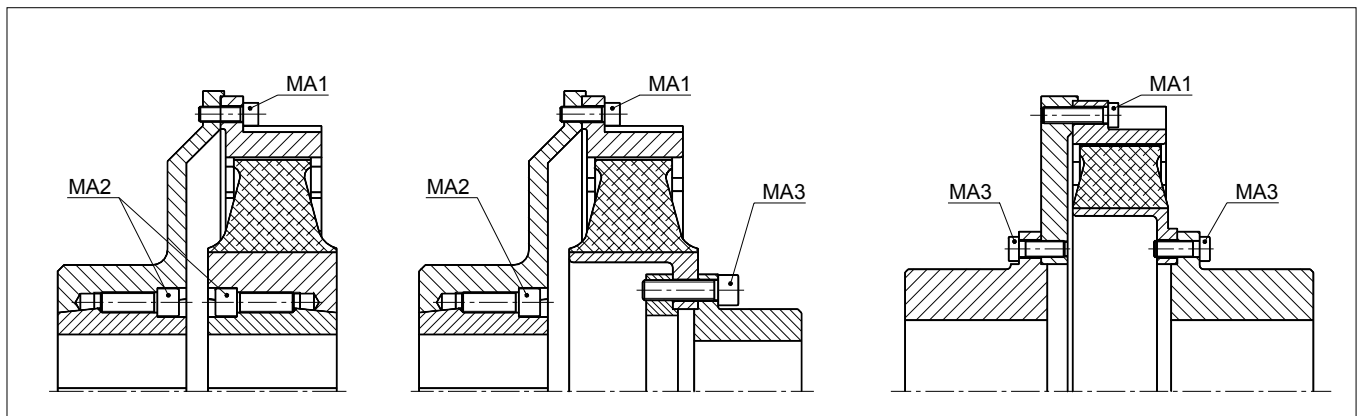

Coupling size	AC 2,3	AC 2,6 / AC 3 AC 4 / AC 4.1 AC 5 / AC 5.1	AC 6 / AC 6.1 AC 6,5 AC 7	AC 8 / AC 8D AC 9 / AC 9D		AC 10 AC 11 / AC 11,6 AC 12	
Bolt size (metric)	M8	M10	M12	M16	M20	M20	M24
Tightening torque M <sub>A1</sub> [Nm]	25	50	85	210	420	420	710

For the tightening torques M<sub>A2</sub>, see the mounting instructions for taper bushes, table 2.  
For the tightening torques M<sub>A3</sub>, see table 3.

## Alignment

Careful alignment of the coupling is an essential requirement for detached, non-flanged machinery in order to ensure proper functioning of the coupling and to avoid premature wear of the rubber element.

Flywheel couplings shall be aligned from the shaft-side coupling half to either one of the machined surfaces of the engine flywheel or engine housing. Where shaft couplings are used, the angular and radial displacements between the two coupling halves are determined by applying the usual dial indicator method. The alignment rules of the other application components have to be considered.

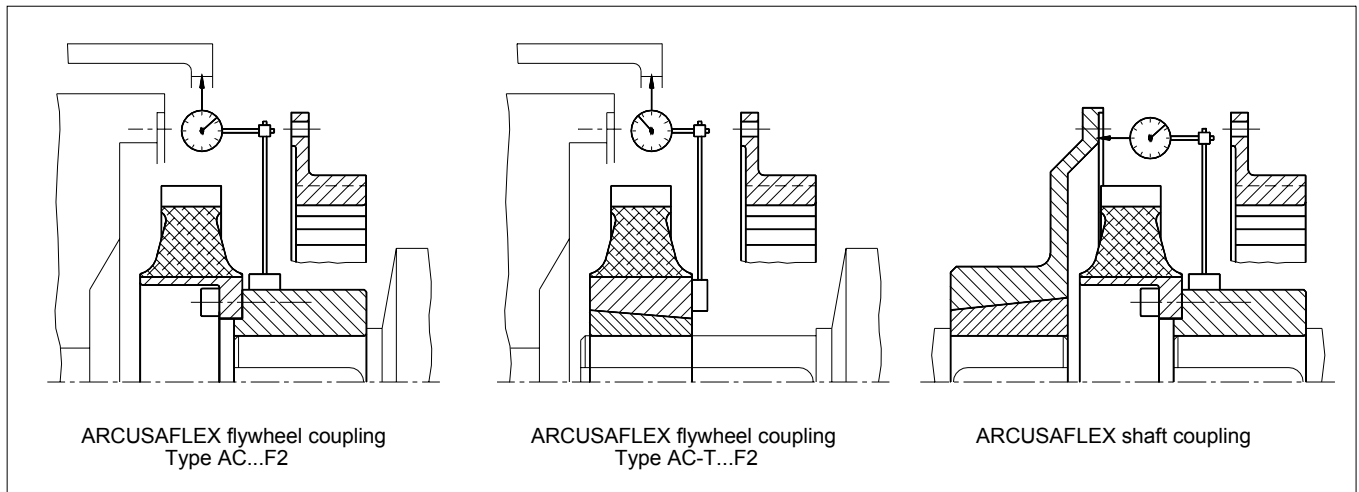

## Permissible shaft displacement

The permissibility of major shaft displacements depends on a number of factors such as coupling size, shore hardness of the rubber element, operating speed and torque load of the coupling. The following reference values refer to an operating speed of  $\approx 1500$  rpm.

Precise alignment of the shaft orientation prevents premature wear of the rubber element.

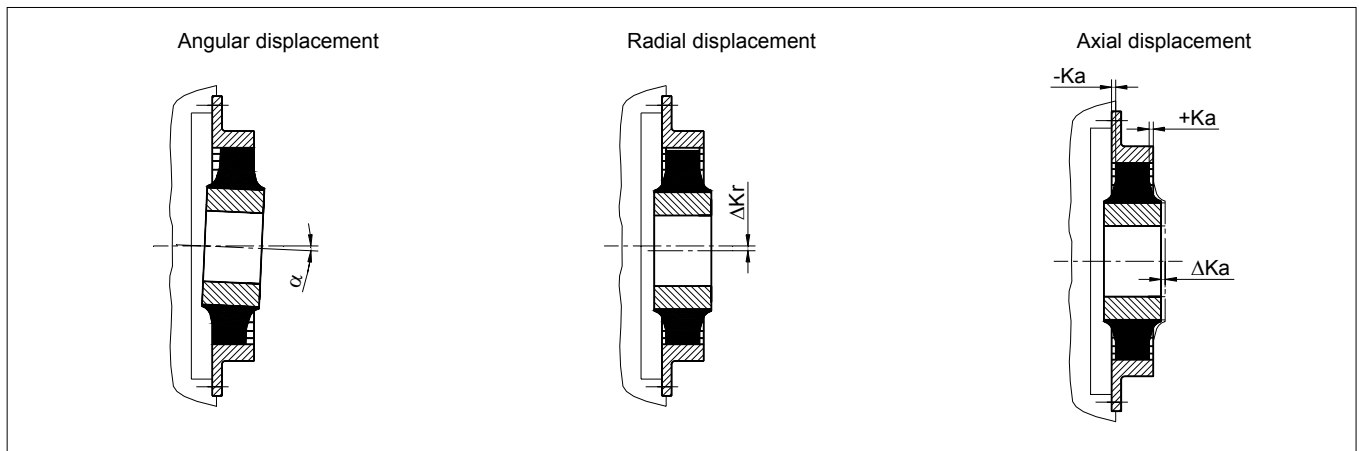

ARCUSAFLEX coupling size	2,3	2,6	3	4	5	6	6,5	7	8 8D	9 9D	10 10D	11 11D	11,6	12 12D
Permissible radial displacement $\Delta Kr$ [mm]	1.2	1.2	1.2	1.2	1.2	1.3	1.3	1.3	1.4	1.5	1.5	1.5	1.5	1.5
Permissible angular displacement $\alpha$ [°]	0.5°	0.5°	0.5°	0.5°	0.5°	0.4°	0.4	0.4°	0.4°	0.4°	0.3°	0.3°	0.3	0.3°
Permissible axial displacement $\Delta Ka$ [mm] *)	$\pm 3$	$\pm 4$	$\pm 7$	$\pm 6$	$\pm 5$	$\pm 7$	$\pm 4$	$\pm 10$	$\pm 7$	$\pm 4$	$\pm 3$	$\pm 4$	$\pm 4$	$\pm 3$

Larger displacements of short duration, as they may occur when starting and stopping the diesel engine, are permissible. The maximum displacements must not occur simultaneous.

\*) At types AC...F2K and AC...TK the axial fitting length  $L_F$  of the coupling should always offer a plus tolerance within the possible tolerance range in order to reach max. axial movability of the dismantled coupling element.

## Safety precautions

It is the customer's and user's responsibility to provide proper guards over rotating machinery and to observe the national and international safety rules and laws.

Check all bolted connections for proper fit preferably after the test run.

### Maschinenfabrik Dipl.-Ing. Herwarth Reich GmbH

Vierhausstr. 53 D-44807 Bochum  
Tel.: +49/(0)234 / 95916-0  
Internet: www.reich-kupplungen.de

P.O. Box 10 20 66 D-44720 Bochum  
Fax: +49/(0)234 / 9591616  
E-mail: mail@reich-kupplungen.de